

Contact Details

Before using the product, please check the guide pages at the front of this catalog.

Internet

<http://www.daikinpmc.com/en/>

For latest information, PDF catalogs and operation manuals

Digital Pressure Control Valve with Handle



Features

- Digitally displays the rotational position of the pressure adjusting handle.
- Extremely convenient in applications where frequent pressure adjustment is required

Specifications

Scale change per revolution	Handle turning torque N·m {kgf·cm}	Mass kg
100	0.4 {4} maximum	0.4

External dimension diagram

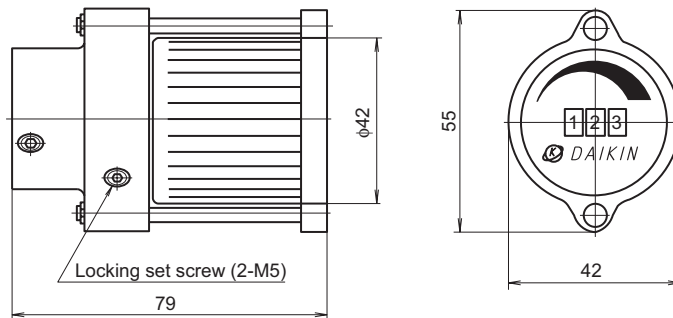

Guide to model codes

10 Option code
D: With digital handle

11 Direction of the digital handle
U: Digital scale oriented upward
D: Digital scale oriented downward <Applicable only to the screw connection type (T)>
R: Digital scale oriented rightward
L: Digital scale oriented leftward

● Direct operated relief valve

※ - **JR** - ※ **02** - ※ - **22** - **D** ※

1 2 3 4 5 6 10 11

※ - **CR** - **G** **02** ※ - ※ - **10** - **D** ※

1 2 3 4 5 6 7 10 11

3 Connections

G: Gasket type

6 Pressure adjustment range

- 1: 1.5 to 7 MPa {15 to 70 kgf/cm²}
- 2: 1.5 to 16 MPa {15 to 160 kgf/cm²}
- 3: 1.5 to 25 MPa {15 to 250 kgf/cm²}

SR - ※ **03** - **1** - ※ ※ - **D** ※

1 2 3 4 5 10 11

4 Pressure adjustment range

- 1: 0.3 to 5 MPa {3 to 50 kgf/cm²}

※ - **HDRIR** - ※ **02** - **1** - **D** ※

1 2 3 4 5 10 11

5 Pressure adjustment range

- 1: 0.9 to 7 MPa {9 to 70 kgf/cm²}

Contact Details

Before using the product, please check the guide pages at the front of this catalog.

Internet

<http://www.daikinpmc.com/en/>

For latest information, PDF catalogs and operation manuals

● Pilot operated relief valve

※ - **HDRI** - ※ **03** - ※ ※ - **D** ※
 1 2 3 4 5 6 10 11

※ - **JRB** - ※ ※ ※ - ※ ※ - ※ ※ - ※ - **D** ※
 1 2 3 4 5 6 7 8 10 11

3 Connections

G: Gasket type

T: Screw connection type

● Solenoid operated relief valve

※ - **JRS** - ※ ※ ※ - ※ ※ - ※ ※ - **40** - **D** ※
 1 2 3 4 5 6 7 8 9 10 11

● Type C2 low-pressure relief valve

※ - **C2RL** - **G** ※ ※ - ※ - **10** - ※ - **D**
 1 2 3 4 5 6 7 10

10 Option code

D: With digital handle (digital scale oriented upward)

● Reducing valve

※ - **SGB** - **G** **03** - **1** - **20** - ※ ※ - **D** ※
 1 2 3 4 5 6 7 10 11

● Type C2 low-pressure reducing valve

※ - **C2GL** - **G** ※ ※ - ※ - **10** - **D**
 1 2 3 4 5 6 10

10 Option code

D: With digital handle (digital scale oriented upward)

● Relief reducing valve

※ - **SGR** - **G** ※ ※ - ※ - **10** - **D** ※
 1 2 3 4 5 6 10 11

4 Nominal diameter

02: ¼

03: ⅜