

## Contact Details

Before using the product, please check the guide pages at the front of this catalog.

Internet

<http://www.daikinpmc.com/en/>

For latest information, PDF catalogs and operation manuals

## Performance curves

Fluid temperature - Flow rate characteristics

Oil usable	Pressure difference between inlet and outlet ports	Standard flow rate
Equivalent to ISO VG32	3 MPa {30 kgf/cm <sup>2</sup> }	Flow rate at fluid temperature of 20°C

SF-G02-030

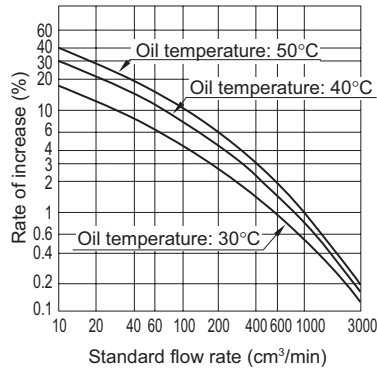

SF-G02-060

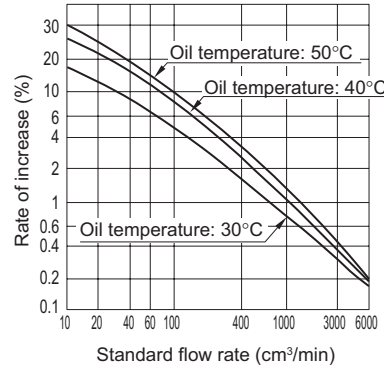

SF-G02-150

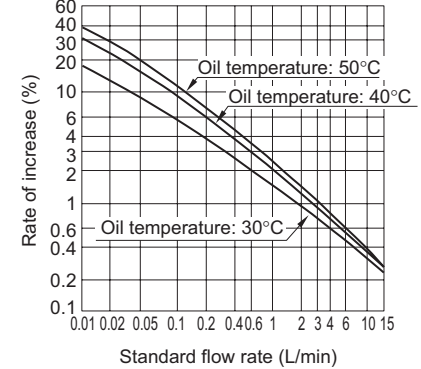

## External dimension diagram

SF-G02

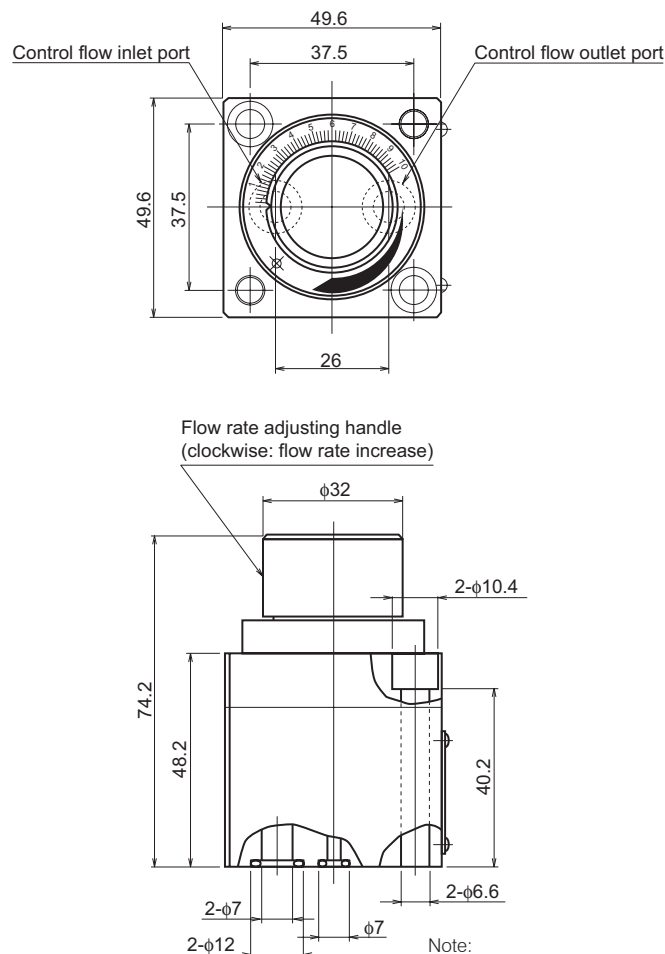

Note:  
This port has no influence on the operation of the valve, but seal it with the gasket face.

## Sectional structural diagram

SF-G02

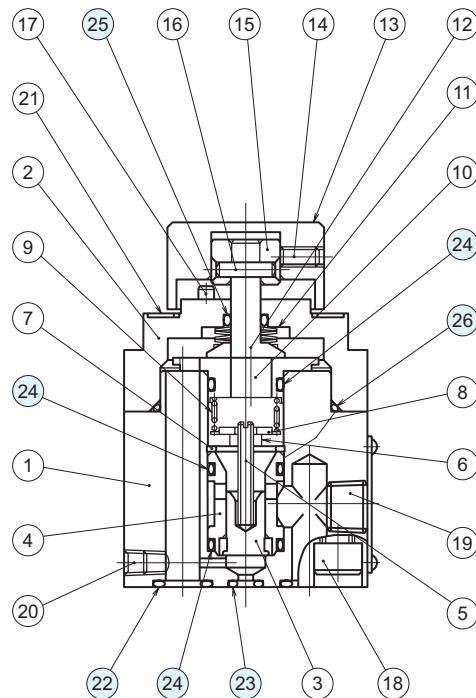

Sealing part table

Part No.	Name	Quantity	Part specifications
22	O-ring	2	JIS B 2401 1A P9
23	O-ring	1	JIS B 2401 1A P4
24	O-ring	3	AS568-014 (NBR,Hs70)
25	O-ring	1	JIS B 2401 1A P6
26	O-ring	1	AS568-028 (NBR,Hs70)