

## Contact Details

Before using the product, please check the guide pages at the front of this catalog.

Internet

<http://www.daikinpmc.com/en/>

For latest information, PDF catalogs and operation manuals

# Check Valve (for SF-G02, ST-G02)

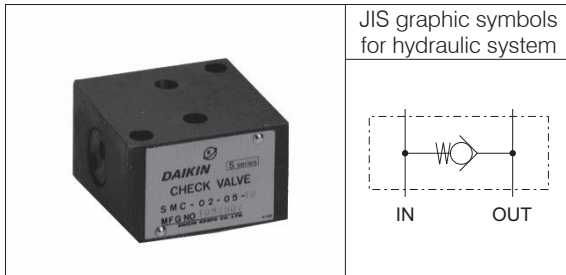

## Features

- These check valves are for flow control valve SF-G02 and throttle valve ST-G02 to be stacked below SF-G02 or ST-G02.

## Nomenclature

※ - SMC - 02 - 05 - 10

### 1 Applicable fluid code

No designation: Petroleum-based hydraulic fluid, water-glycol hydraulic fluid  
 F: Phosphate ester hydraulic fluid

### 2 Model No.

SMC: Check valve for S series flow control valve

### 3 Nominal diameter

02: ¼

### 4 Cracking pressure code

05: 0.05 MPa {0.5 kgf/cm<sup>2</sup>}

### 5 Design No.

(The design No. is subject to change)

## Specifications

Model code	Nominal diameter	Maximum operating pressure MPa {kgf/cm <sup>2</sup> }	Maximum flow rate L/min	Cracking pressure MPa {kgf/cm <sup>2</sup> }	Mass kg
SMC-02-05-10	¼	7 {70}	30	0.05 {0.5}	0.5

## Handling

- Mounting bolts are not provided with the valve. Use the bolts indicated below.

Stack valve model	Hexagon socket head cap screws	Quantity	Tightening torque N·m {kgf·cm}
SF-G02	M6 × 80	2	10 to 12.5 {100 to 125}
ST-G02	M6 × 60	2	10 to 12.5 {100 to 125}

- Order SF-02M separately as the sub-plate. Refer to Page S-7 for the dimensions of the sub-plate.

## Performance curves (viscosity: 32 mm<sup>2</sup>/s {cSt})

### Pressure drop characteristics

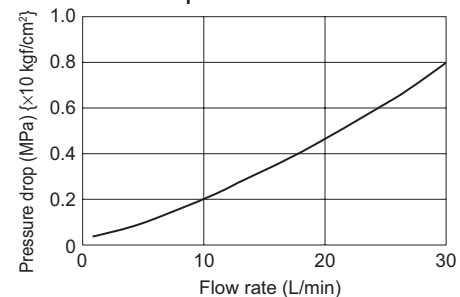

## External dimension diagram

SMC-02

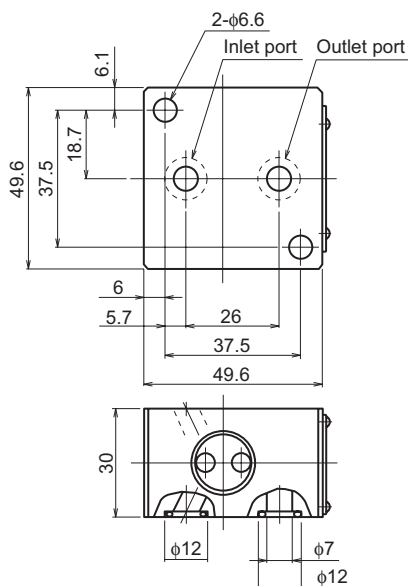

## Sectional structural diagram

SMC-02

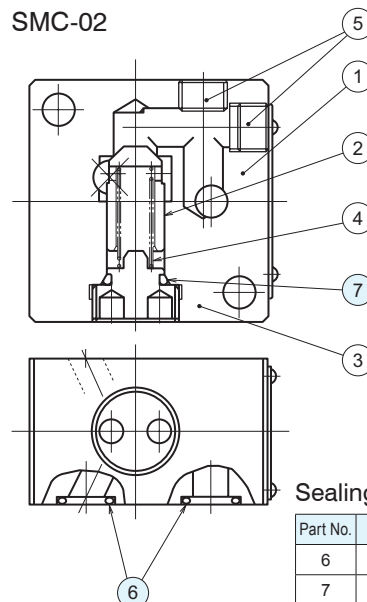

### Sealing part table

Part No.	Name	Quantity	Part specifications
6	O-ring	2	JIS B 2401 1B P9
7	O-ring	1	JIS B 2401 1B P10

FLOW CONTROL VALVES F