

Contact Details

Before using the product, please check the guide pages at the front of this catalog.

Internet

<http://www.daikinpmc.com/en/>

For latest information, PDF catalogs and operation manuals

Flow Control Valve with Digital Handle



Features

- Digitally displays the rotational position of the pressure adjusting handle.
- Extremely convenient in applications where frequent pressure adjustment is required

Specifications

Scale change per revolution	Handle turning torque N·m {kgf·cm}	Mass kg
100	0.4 {4} maximum	0.4

External dimension diagram

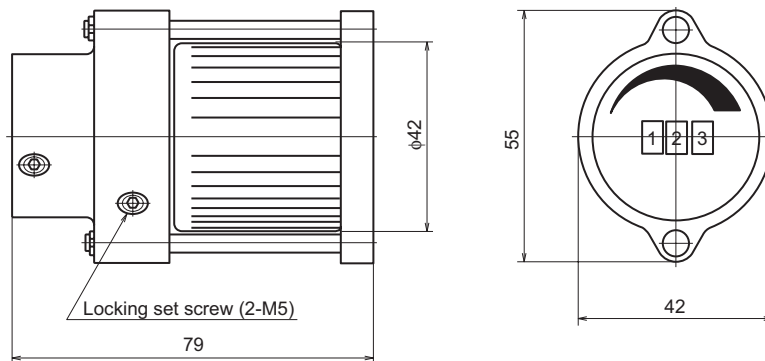

Nomenclature

● Flow control valve

※ - **JF** ※ - **G** ※※ - ※※※ - ※※ ※ **D** ※
 1 2 3 4 5 6 7 9 10 11

● Throttle valve

※ - **HDFT** ※ - ※ ※※ **D** ※
 1 2 3 4 5 10 11

10 Option code

D: With digital handle

11 Direction of the digital handle

U: Digital scale oriented upward
 D: Digital scale oriented downward
 R: Digital scale oriented leftward
 L: Digital scale oriented rightward

Note: With JF(C)-G※※, it is not possible to select the specifications with the digital handle if specifications with the flow rate adjustment handle locking key (option code: L) are selected.