

## Contact Details

Before using the product, please check the guide pages at the front of this catalog.

Internet

<http://www.daikinpmc.com/en/>

For latest information, PDF catalogs and operation manuals

# Solenoid Pilot Operated Directional Control Valve

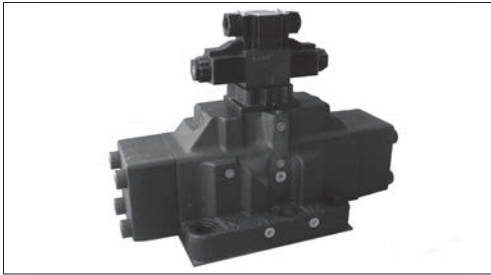

## Features

- These models realize high-pressure large-flow-rate control at 35 MPa {350 kgf/cm<sup>2</sup>} and 1100 L/min.

## Nomenclature

※ - **KSH** - **G 10** - ※※ ※ ※ - **20** - ※ ※ - ※

1 2 3 4 5 6 7 8 9 10 11

### 1 Applicable fluid code

No designation: Petroleum-based hydraulic fluid  
Water-glycol hydraulic fluid  
F: Phosphate ester hydraulic fluid

### 2 Model No.

KSH: K series solenoid pilot operated directional control valve

### 3 Connections

G: Gasket mount type

### 4 Nominal diameter

10: 1¼

### 5 Spool type (See the model table)

### 6 Spool operating method (See the model table)

C: Spring center type  
B: Spring offset type (with SOL.b)

### 7 Voltage code (See the voltage code table)

### 8 Design No. (The design No. is subject to change)

### 9 Main valve option code (See the option code table)

### 10 Solenoid pilot valve option code

Refer to the option code table for KSO-G02 on Page G-16

### 11 Pilot stack valve code (See the option code table)

Note: The maximum number of digits in the model code is limited to 23. Combining the codes for the specifications above may exceed the limit of 23 digits. In such cases, select the codes to be designated according to the functional importance of each specification and restrict the model code to 23 digits with the non-standard number appended. Contact Daikin about individual cases.

## Specifications

Model No.	Nominal diameter	Maximum operating pressure MPa {kgf/cm <sup>2</sup> }	Maximum flow rate L/min	Pilot pressure MPa {kgf/cm <sup>2</sup> } *1		Permissible back pressure MPa {kgf/cm <sup>2</sup> }		Maximum switching frequency times/min
				(1)	(2)	External drain type	Internal drain type	
KSH-G10	1¼	35 {350}	1100	(1)	1.0 to 35 {10 to 350}	21 {210}	16 {160}	120 *2
				(2)	0.5 to 35 { 5 to 350}			

Note: \*1 The pilot pressure varies depending on the following structure.

(1)	For spool types other than 3 and 66
(2)	For spool types 3 and 66

Note: \*2 The maximum switching frequency of the DIN connector type with built-in surge killer (option code: N-CL(E)) is 100 times/min.

Refer to KSO-G02 on Page G-16 for the solenoid specifications.

Spool operating method	Fluid drainage volume at spool switching cm <sup>3</sup>
Type C	32.4
Type B	64.8

## 7: Voltage code table

Voltage code	Power supply voltage	Voltage code	Power supply voltage
A	AC 100 V (50/60 Hz), AC 110 V (60 Hz)	N	DC 12 V
B	AC 200 V (50/60 Hz), AC 220 V (60 Hz)	P	DC 24 V
C	AC 110 V (50 Hz)	Q	DC 48 V
D	AC 220 V (50 Hz)	R	DC 100 V
J	AC 240 V (50/60 Hz)	S	DC 110 V
K	AC 120 V (50/60 Hz)	T	DC 200 V
L	AC 115 V (50/60 Hz)	U	DC 220 V
M	AC 230 V (50/60 Hz)	E	AC 100 V (50/60 Hz) with rectifier
		F	AC 110 V (50/60 Hz) with rectifier
		G	AC 200 V (50/60 Hz) with rectifier
		H	AC 220 V (50/60 Hz) with rectifier

See the solenoid specification table for KSO-G02 on Page G-16 for solenoid specifications.

## Contact Details

Before using the product, please check the guide pages at the front of this catalog.

Internet

<http://www.daikinpmc.com/en/>

For latest information, PDF catalogs and operation manuals

## 9 10 11: Option code table

9 Code	Option details
No designation	Internal pilot, external drain type
X	Internal pilot, internal drain type
Y	External pilot, external drain type
Z	External pilot, internal drain type
T	With check valve for pilot pressure

11 Code	Option details <sup>*3</sup>
No designation	Without stack valve
W	With MT-02W-60
R	With MG-02P-1-60-S02
RR	With MG-02P-1-60-R02
G	With MT-02W-60, MG-02P-1-60-S02
GR	With MT-02W-60, MG-02P-1-60-R02

Note: ○ If two or more options are selected, sort the option codes, separately for option types 9 and 10, in alphabetical order.

○ When using spool type 3 or 66 as the internal pilot type, select the main valve option specifications with a check valve for pilot pressure (option code: T).

<sup>\*3</sup> With MT-02W-60: To be selected for applications where shocks at switching need to be suppressed

With MG-02P-1-60-×02: To be selected for applications where an operating pressure beyond 25 MPa {250 kgf/cm<sup>2</sup>} is required

## Mass (kg)

Details		AC	DC, with rectifier
Terminal box type	Double solenoid	45.5	45.9
	Single solenoid	45.2	45.4
DIN connector type	Double solenoid	45.5	45.8
	Single solenoid	45.1	45.3
Lead wire type	Double solenoid	45.4	45.7
	Single solenoid	45.1	45.2

Note: With the following options, the mass will be increased by the mass given for each option.

Details	Code	Mass kg
With MT-02W-60	W	1.4
With MG-02P-1-60-×02	R, RR	1.3
With MT-02W-60, MG-02P-1-60-×02	G, GR	2.7

## Solenoid pilot valve model code

Model code	Applicable solenoid valve model code (×: Voltage code)
KSH-G10-××C×-20	KSO-G02-4C×-30
KSH-G10-××B×-20	KSO-G02-2B×-30

## Accessories

Hexagon socket head cap bolt	Quantity	Tightening torque N·m {kgf·cm}
M20 × 65	6	428 to 475 {4280 to 4750}

## Sub-plate model code

● The sub-plate is not provided with the valve. Order it separately if required by specifying the model code given in the table below.

Model code	Nominal diameter	Connection port diameter	Mass kg
JS-10M	1¼	Rc1¼	17
JS-10M12		Rc1½	

Refer to Page S-9 for the dimensions of the sub-plate.

## 5 6: Model table

Model code	JIS graphic symbols for hydraulic system	Maximum flow rate L/min					Pressure drop characteristics (See the performance curves)		
		Pressure MPa {kgf/cm <sup>2</sup> }					P → A P → B	A → T B → T	P → T
		7 {70}	14 {140}	21 {210}	28 {280}	35 {350}			
KSH-G10-2C		1100	1078	1022	832	757	(6)	(6) (5)	-
KSH-G10-3C		946	889	851	757	662	(2)	(1) (2)	(3)
KSH-G10-4C		1100	1078	1022	832	757	(6)	(2)	-
KSH-G10-66C		946	889	851	757	662	(4)	(4)	(1)
KSH-G10-2B		1100	1078	1022	832	757	(6)	(6) (5)	-
KSH-G10-3B		1100	1078	1022	832	757	(2)	(1) (2)	(3)

Note 1: In the transient period of switching, all ports are blocked with spool type 66C.

2: The maximum flow rates given in the table above are the values with the flow P → A → B → T (or P → B → A → T) as shown in the diagram to the right.

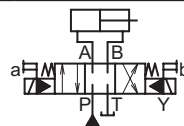

## Contact Details

Before using the product, please check the guide pages at the front of this catalog.

Internet

<http://www.daikinpmc.com/en/>

For latest information, PDF catalogs and operation manuals

## Performance curves (Viscosity: 35 mm<sup>2</sup>/s {cSt})

### Pressure drop characteristics

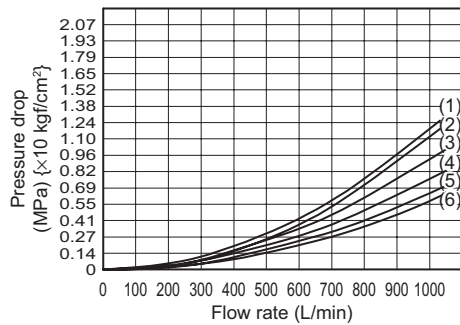

## Handling

### ● Pilot

- With the internal drain type, maintain the pressure difference between the pilot pressure and the back pressure of the tank line no lower than the minimum pilot pressure.
- When using the product with spool type 3 or 66 as the internal pilot type, insert a resistance valve with a cracking pressure of 0.5 MPa minimum in the tank line and set it as the external drain type. Or, select the main valve option specifications with check valve for pilot pressure (option code: T).
- With the internal pilot type products, block the X port on the mounting face.

### ● Drainage

- Directly connect the drain piping to the tank without merging it with other tank piping.
- External pilot type products can be used as internal drain type regardless of the model.
- Internal pilot type products can be used as internal drain type when the spool type is 2, or 4.
- With internal drain type products, block the Y port on the mounting face.

### ● Tightening torque of pilot valve mounting bolts (M5): 6.5 to 8.5 N·m {65 to 85 kgf·cm}

## Pilot/drain type setting guide

- Either the internal or external pilot and drain types can be set by fitting/removing plugs.

When changing the pilot setting from internal pilot type to external pilot type, one additional dry seal taper thread plug (NPTF<sup>1</sup>/<sub>8</sub>) will be necessary. Order one separately.

When changing the drain setting from internal drain type to external drain type, one additional dry seal taper thread plug (NPTF<sup>1</sup>/<sub>8</sub>) will be necessary. Order one separately.

View of the main valve from above without the solenoid pilot valve and adapter plate

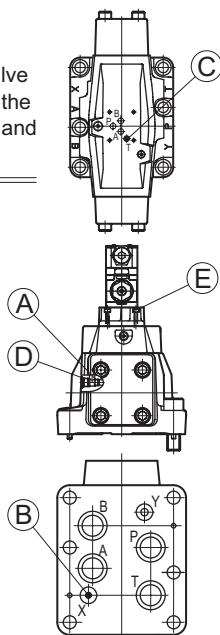

### [Pilot/drain type setting guide]

Code	Pilot/drain type	Position A	Position B (Port X)	Position C
No designation	Internal pilot, external drain	φ3.2 With fixed throttle	Without plug	With plug
X	Internal pilot, internal drain	φ3.2 With fixed throttle	Without plug	Without plug
Y	External pilot, external drain	With plug	φ3.2 With fixed throttle	With plug
Z	External pilot, internal drain	With plug	φ3.2 With fixed throttle	Without plug

Note: When fitting a plug at position A, remove the plug with flange at position D and tighten the plug at the torque given below.

### [Tightening torque at each section]

Product name	Tightening torque N·m {kgf·cm}
Hexagon socket head cap bolt (M5)	6.5 to 8.5 { 65 to 85 }
Hexagon socket plug (NPTF <sup>1</sup> / <sub>8</sub> ): Position A, B, C	11.1 to 12.8 {111 to 128}
Hexagon socket plug (1/2-20UNF): Position D	20.5 to 22.5 {205 to 225}
Hexagon socket plug (1/4-20UNRC-3A): Position E	14.0 to 15.4 {140 to 154}

Note: Do not wrap the plugs with sealing tape.

# Contact Details

Before using the product, please check the guide pages at the front of this catalog.

Internet

<http://www.daikinpmc.com/en/>

For latest information, PDF catalogs and operation manuals

## External dimension diagram

- Spring center type [type C]  
(Hexagon socket head cap bolts used: M5 × 45, 4 pcs.)

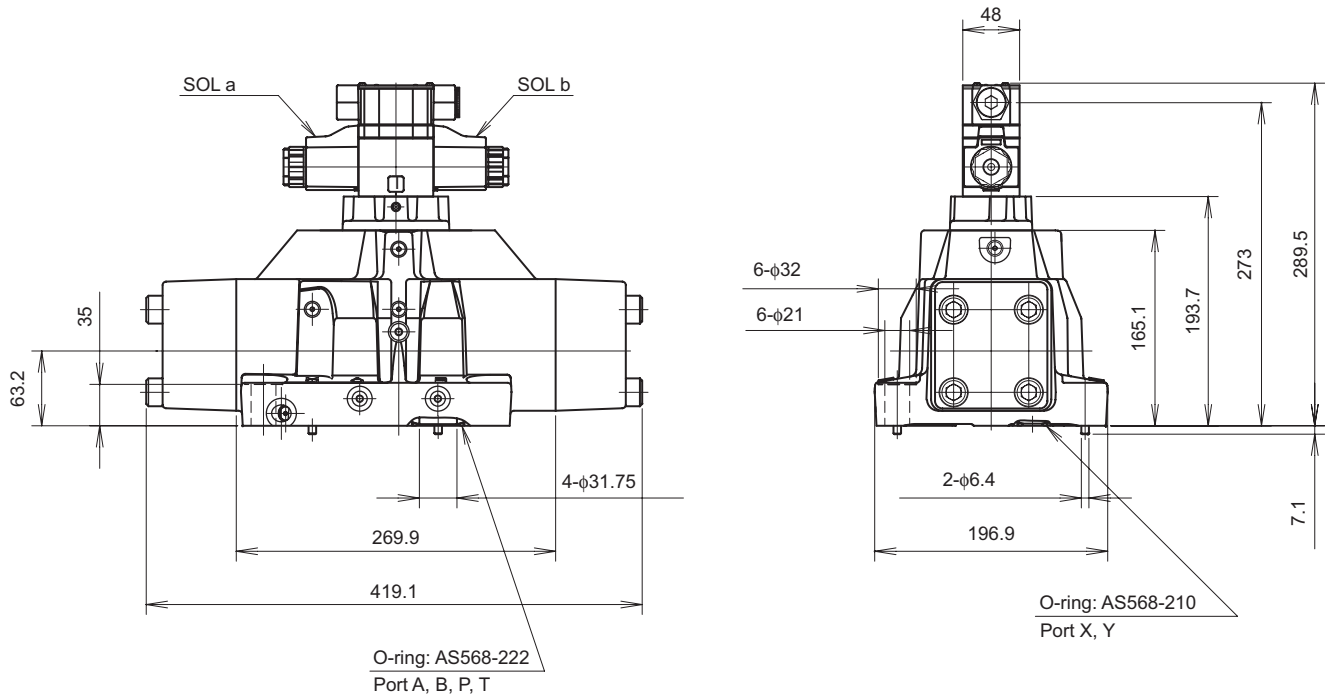

Mounting face (conforming standard)  
ISO 4401-10-09-0-05

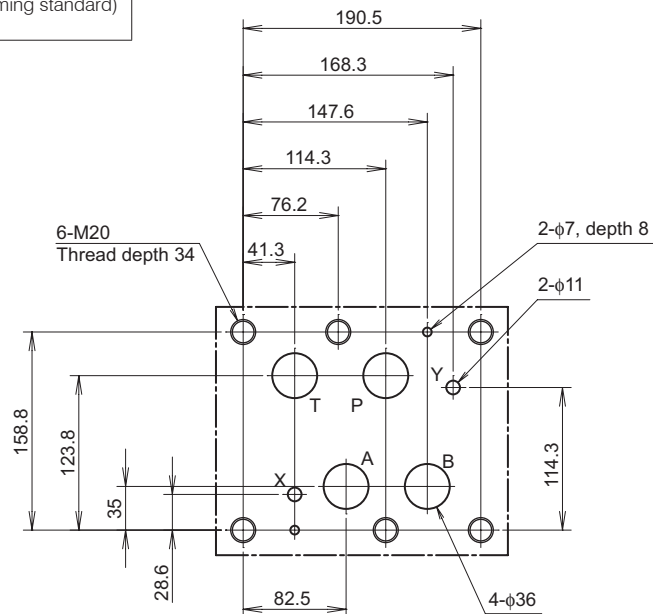

## Contact Details

Before using the product, please check the guide pages at the front of this catalog.

Internet

<http://www.daikinpmc.com/en/>

For latest information, PDF catalogs and operation manuals

## External dimension diagram

- Spring offset type (type B)  
(Hexagon socket head cap bolts used: M5 × 45, 4 pcs.)

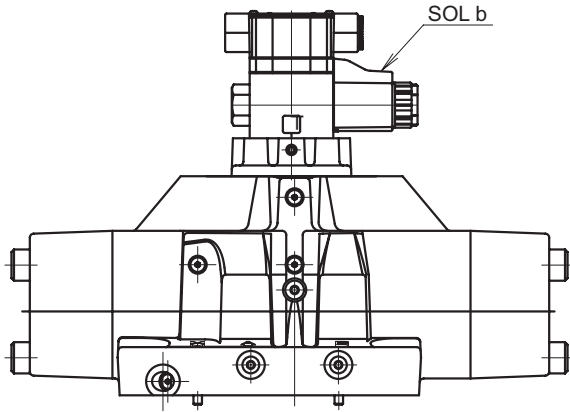

- ★ O2 series stack valve added in the pilot line
- With MG-02P-1-60-×02 (type R, RR)  
(Hexagon socket head cap bolts used: M5 × 85, 4 pcs.)

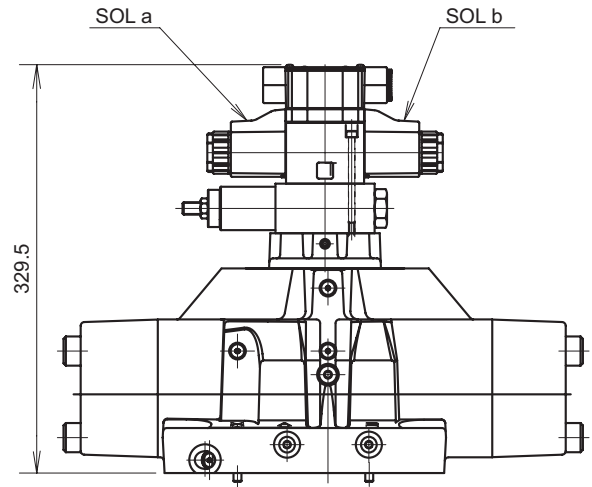

- MT-02W-60  
With MG-02P-1-60-×02 (type G, GR)  
(Hexagon socket head cap bolts used: M5 × 125, 4 pcs.)

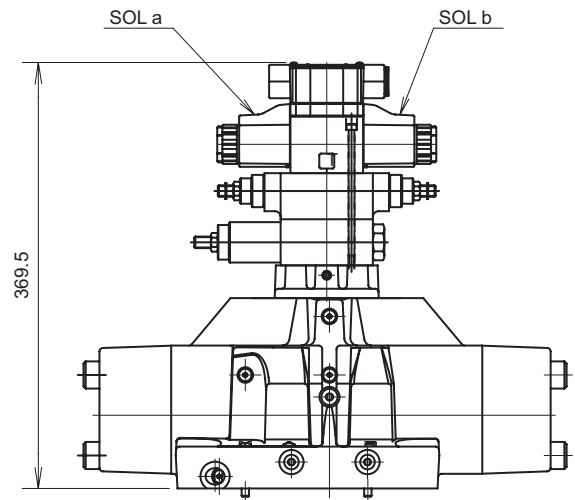

- With MT-02W-60 (type W)  
(Hexagon socket head cap bolts used: M5 × 85, 4 pcs.)

