

Contact Details

Before using the product, please check the guide pages at the front of this catalog.

Internet

<http://www.daikinpmc.com/en/>

For latest information, PDF catalogs and operation manuals

02 Series Stacking Type Port A/B Flow Control Valves

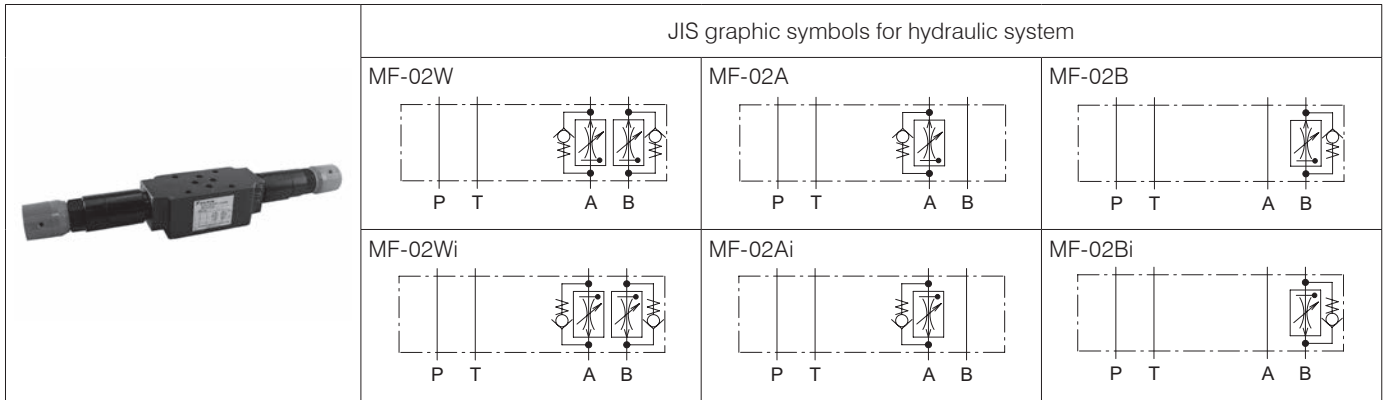

Nomenclature

1 2 3 4 5 6

1 Applicable fluid code

No designation: Petroleum-based hydraulic fluid, water-glycol hydraulic fluid
 F: Phosphate ester hydraulic fluid

2 Model No.

MF: Modular stacking type flow control valve

3 Nominal diameter

02: ¼

4 Control port

W: Port A/B
 A: Port A
 B: Port B

5 Control method

No designation: Meter-out control
 i: Meter-in control

6 Design No. (The design No. is subject to change)

Note: Contact Daikin separately for the delivery term of the products that accept phosphate ester hydraulic fluids.

Specifications

Model code	Maximum operating pressure MPa {kgf/cm ² }	Maximum flow rate L/min	Control flow rate L/min *1		Check valve cracking pressure MPa {kgf/cm ² }	Mass kg
			(1)	(2)		
MF-02W*-55	25 {250}	40	0.1 to 40	0.5 to 40	0.08 {0.8}	2
MF-02A(B)*-55						1.8

Note: *1 Control flow rate (1) Pressure difference between the inlet and outlet ports to be 7 MPa {70 kgf/cm²} maximum
 (2) Pressure difference between the inlet and outlet ports to be 25 MPa {250 kgf/cm²} maximum

Handling

- To ensure good pressure compensation performance, maintain a pressure difference of 1 MPa {10 kgf/cm²} minimum between the inlet and outlet ports.
- The flow rate will not be zero even if the flow rate adjusting handle is fully tightened.

Performance curves (viscosity: 32 mm²/s {cSt})

Pressure difference -
Flow rate characteristics

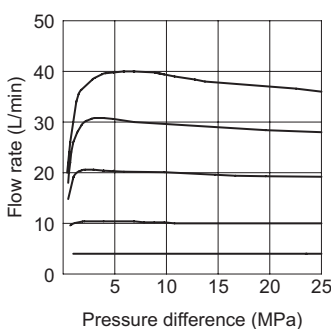

Fluid temperature -
Flow rate characteristics
(Fluid used: equivalent to ISO VG32)

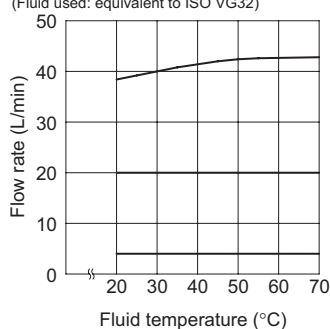

Handle revolution -
Flow rate characteristics

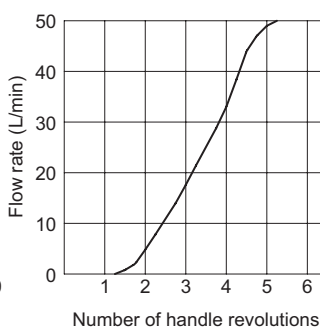

Pressure drop characteristics

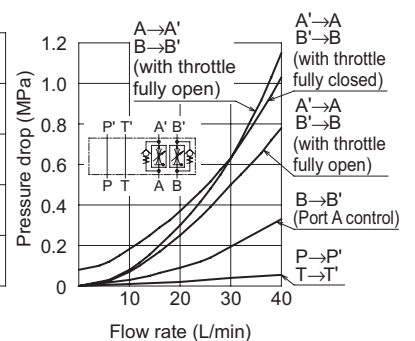

Contact Details

Before using the product, please check the guide pages at the front of this catalog.

Internet

<http://www.daikinpmc.com/en/>

For latest information, PDF catalogs and operation manuals

External dimension diagram

MF-02W-55

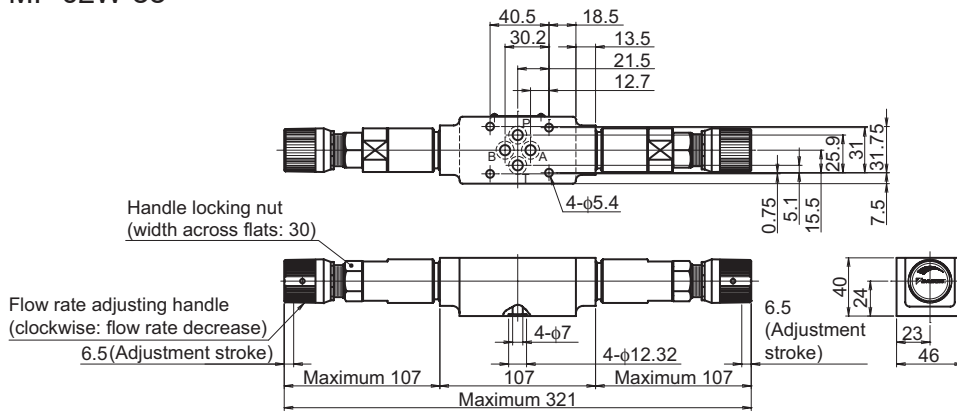

MF-02A-55

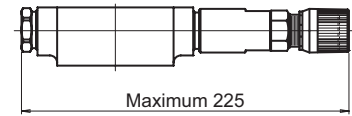

MF-02B-55

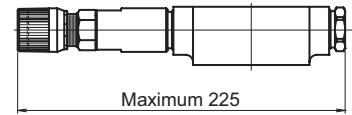

MF-02Wi-55

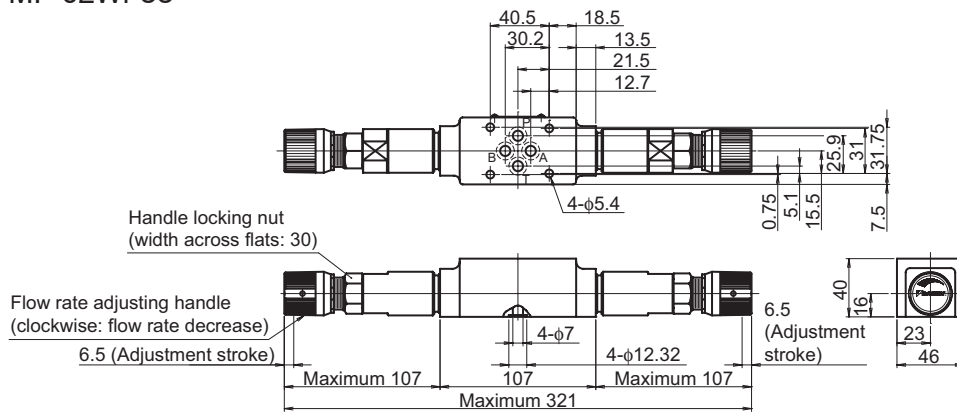

MF-02Ai-55

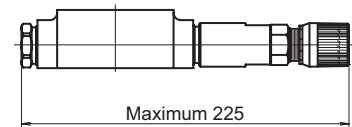

MF-02Bi-55

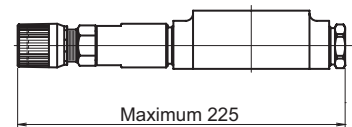

Sectional structural diagram

MF-02W-55

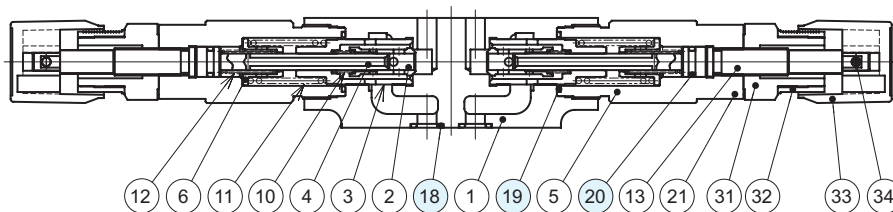

MF-02Wi-55

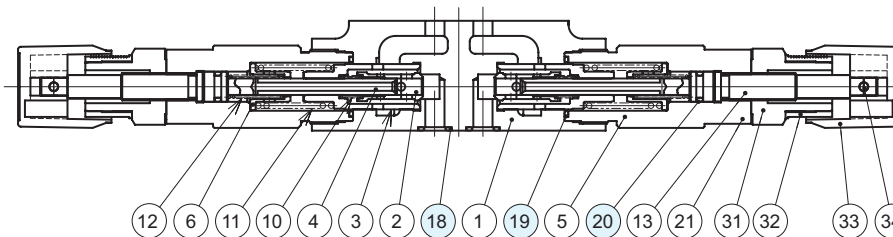

Sealing part table

Part No.	Name	Quantity		Part specifications
		W	A, B	
18	O-ring	4	4	AS568-012 (NBR, Hs90)
19	O-ring	2	2	AS568-018 (NBR, Hs90)
20	O-ring	2	1	JIS B 2401 1A P8